



# 4910 Series AST Self-Primer

Flows to: 6,400 GPM  
Heads to: 120 Feet  
Temperatures to: 120°F



# SERIES 4910 MODEL AST

SINGLE STAGE  
SELF-PRIMER TRASH

Sizes: 2" to 12" Discharge  
Flows: To 6,400 GPM  
Heads: To 120 Feet  
Temp: To 120°F

## Services:

Construction  
Lift Station  
Industrial Process  
Irrigation & Drainage  
Municipal Wastewater Supply

### REMOVABLE CLEAN-OUT PLATE

- Quick access to the interior to remove debris that may have clogged the pump
- Cleanout cover has a removable and renewable wear plate
- The impeller and wear plate can be inspected and replaced without disconnecting piping or removing the power frame assembly
- The cleanout cover can be moved to adjust running clearances

### IMPELLER

- Supplied standard in ASTM A48, class 30 cast iron
- Two vane, semi-open, non-clogging design
- Machined and dynamically balanced prior to assembly
- Can be supplied in optional material upon request

### SUCTION CHECK VALVE

- Heavy duty check valve designed to keep the casing full of liquid when the pump is stopped
- The check valve can be removed without disconnecting the suction piping
- Heavy duty, oil resistant reinforced rubber with valve weight integrated into the valve body

### CASING

- Supplied standard in ASTM A48 class 30 cast iron
- Heavy wall thickness for corrosion allowance and high pressure applications
- Oversized priming chamber for quick priming times
- Large, oversized cleanout plate
- Large fill port with quick disconnect handles
- Optional suction and discharge spool pieces making jobsite installation very easy
- Suction & discharge gauge package with 304 stainless steel buffer tube, fittings and ball valves
- Alternate metallurgy options available upon request

### MECHANICAL SEAL

- Cartridge style that is very easy to remove and replace
- Tungsten Carbide vs. Tungsten Carbide standard construction
- Oil lubricated from a dedicated reservoir allowing for run dry capability
- Integral stainless steel shaft sleeve

### POWER FRAME

- Constructed out of A48 class 30 cast iron
- Complete back pull out allows for easy maintenance
- Two independent oil reservoirs lubricate the mechanical seal and both roller bearings
- Oversized oil eye for oil level indication
- 420 stainless steel shaft
- Adjustment screws allow for impeller to wear plate running clearance adjustment

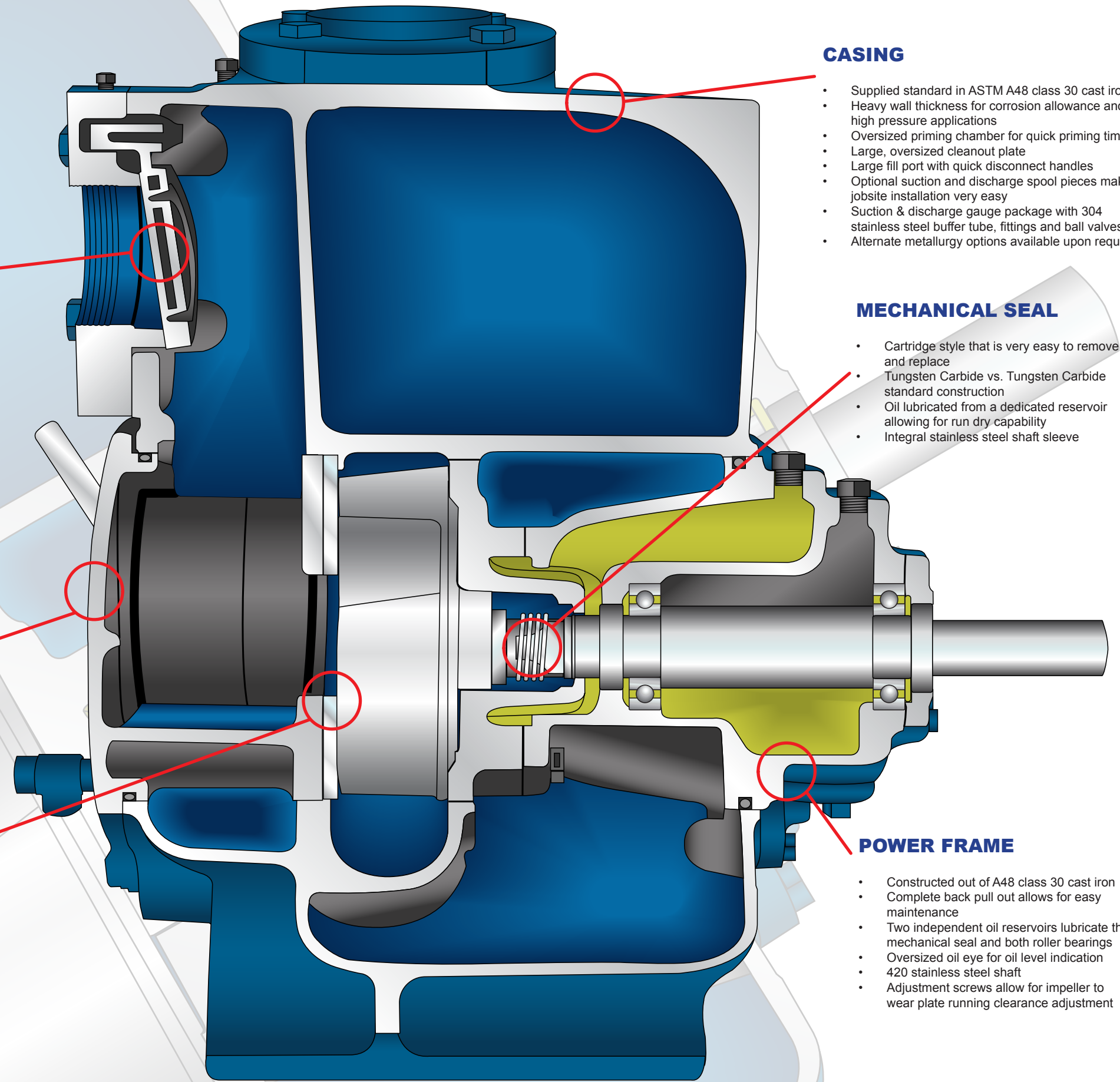



## How It All Began EFFICIENCY BY DESIGN

With years of manufacturing experience, Ameriflo has spent considerable time developing what the customer has asked for. The most diverse hydraulic offering in the self-primer markets with an emphasis on pump efficiency and systems integration. Ameriflo manufactures all product type in a wide variety of standard and optional materials offering you the solution you need.

Ameriflo is a global manufacturer of integrated systems with facilities located in several countries and has clients in over 80 countries. The corporate manufacturing headquarters is located in Tennessee, along with a very large testing and training facility for distributor and representative training.

Ameriflo uses computational fluid dynamics (CFD) and 3D Solids Works for designing all pumps and systems with detail for all valves, suction & discharge piping and any installed optional accessories specified by the end user. Electric and Diesel engine driven systems are available and can be ordered in a variety of flows and pressures with full optional metallurgy support.

### Product Line

The benefit to the Ameriflo offering is that you only need to go to one place for your product line needs. Whether your need is an end suction pump, a large split case or even a vertical turbine Ameriflo has a model for you. Each product line has a very diverse offering from the very small to the very large and everything in between. Do not rely on other manufacturers who have broken product lines with missing models.

Ameriflo also has state-of-the-art engineered customer service. The applications engineering

[www.ameriflo-usa.com](http://www.ameriflo-usa.com)



part of Ameriflo have decades of engineering and specification work. This background and experience is critical when the design engineer is looking for answers to questions.

Ameriflo has one of the largest test facilities in North America with nearly 300,000 gallons of water utilizing 8 different test loops from 2 inch through 36 inch. The horizontal and vertical test labs have ratings up through 1,000 HP and include string test stands allowing testing with the job motor or Diesel engine.

### Communication Is The Key To Our Success

Ameriflo has systems in place making communication with our clients of the utmost priority. Each client has their own customer portal that will allow them to check on all quotations, sales orders and any client case that is generated. These tools put the power in the hands of the client and allow them access to the most current information. This access empowers our clients to respond to their customers in a more timely fashion and secure that next opportunity!

Ameriflo also has a dedicated theater used for sales and service

training. This theater can house approximately 35 students and is used to cover the Ameriflo pump and Diesel engine product lines. Schools are available to sales people and dedicated service schools are also offered. Service schools feature a hands on portion allowing students to disassemble and re-assemble pumps and/or Diesel engines to allow for certified repairs in the field. Contact Ameriflo to inquire about the next school and how you can join in these events.

Ameriflo also has a state-of-the-art software selection package with full configuration, **Ameriflo IQ**, that can be used by simply signing up. E-mail us for additional information.

If you would like more information about what Ameriflo is all about, please contact us.

What separates Ameriflo from the competition, **WE DELIVER.....**

### Ameriflo Corporation

125 Morrison Road  
Rossville, TN 38066  
Phone: (888) 301-6311  
[www.ameriflo-usa.com](http://www.ameriflo-usa.com)

[support@ameriflo-usa.com](mailto:support@ameriflo-usa.com)