



3022 Series

EC

Close-Coupled End Suction



Flows to: 9,000 GPM
Heads to: 450 Feet
Temperatures to: 350°F

SERIES 3022

MODEL EC

SINGLE STAGE
CLOSE-COUPLED END SUCTION

Sizes: 1.25" to 12" Discharge

Flows: To 9,000 GPM

Heads: To 450 Feet

Temp: To 350°F

Services:

Cooling Water

Raw Water Intake

Sea Water

Industrial Process

Condenser Circulating

Irrigation & Drainage

Municipal Water Supply

SHAFT ASSEMBLY

- 420 stainless steel shaft is stronger than standard carbon steel and has superior corrosion resistance
- Designed and sized specifically for the aggressive fire protection markets

CASE WEAR RINGS

- Supplied in standard bronze or other specified alloy
- Case wear rings are renewable which will renew factory running clearances and performance

IMPELLER

- Supplied standard in investment cast, 304 stainless steel
- Francis design allows for hydraulically balanced design with broad band, high efficiency performance
- Machined and dynamically balanced prior to assembly

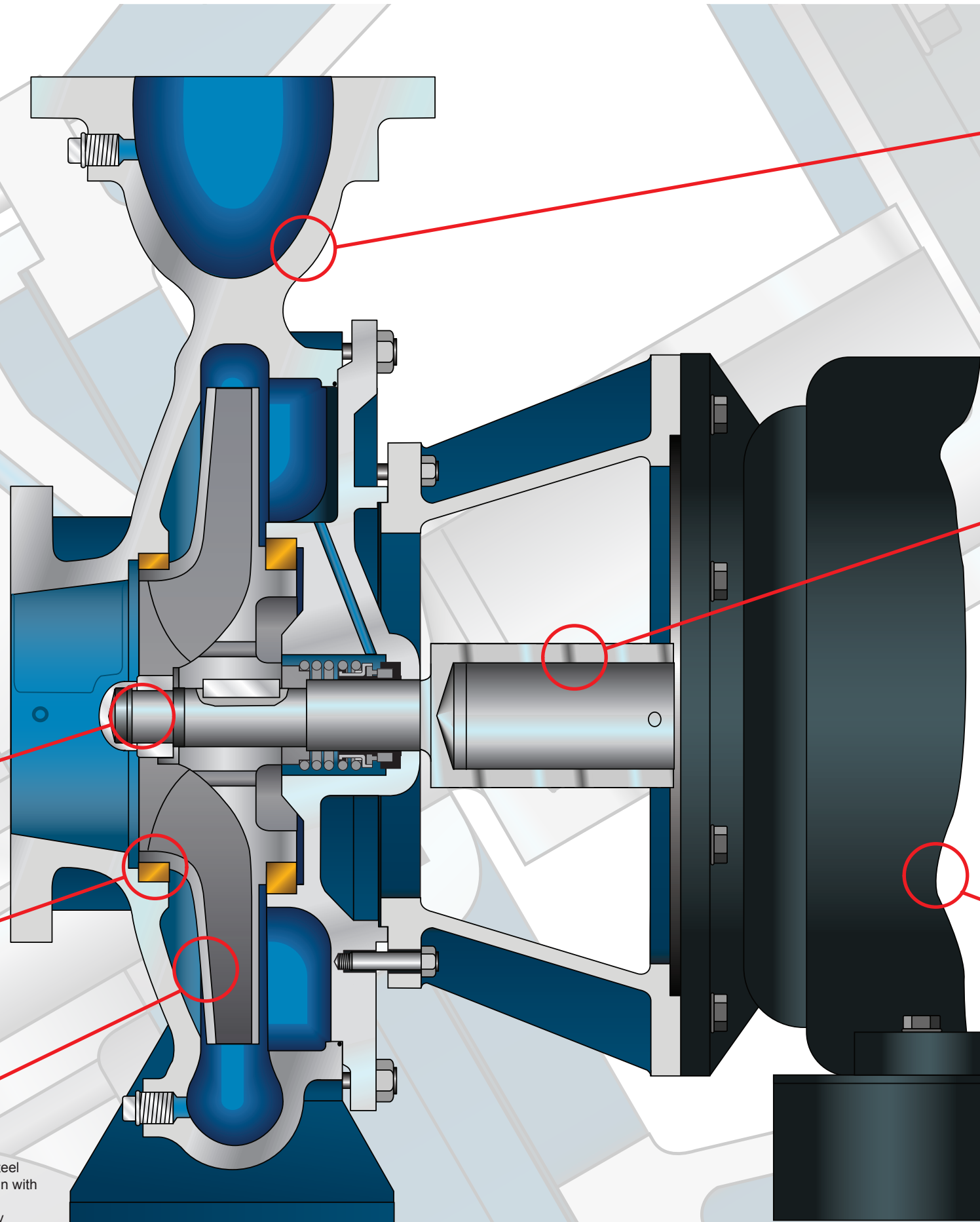

CASING

- Supplied standard in ASTM A48 class 30 cast iron
- Heavy wall thickness for corrosion allowance and high pressure applications
- Axially split to permit complete access to the rotating assembly
- Casing assembly design features pry bar locations to aid in the casing top removal
- Cast integral, vortex suppressor at impeller eye designed to reduce vortexing of fluid prior to it entering the impeller eye
- Threaded taps for gauges and pressure relief valve
- Dedicated cast feet for proper casing support
- Internal flush plan for packing or mechanical seal lubrication
- Suction & discharge gauge package with 304 stainless steel buffer tube, fittings and ball valves
- Suction and discharge flanges supplied in 125 or 250 PSI rating for high pressure applications
- Alternate metallurgy options available upon request

ROTATING ASSEMBLY

- Includes investment cast, 304 stainless steel, single suction impeller
- Modular design maximizes the sharing of common components
- 304 stainless steel shaft sleeves completely protect the shaft from wear and corrosion
- Packing, component, single cartridge and/or double cartridge mechanical seals can be supplied upon request

C-FACE MOTOR

- Complete back pull-out assembly allows for very easy servicing of the complete assembly
- Motors are available in ODP, TEFC and Explosion-Proof designs
- Readily available and stocked
- NEMA 56C to 449TC design using modular design and common components



How It All Began EFFICIENCY BY DESIGN

With years of manufacturing experience, Ameriflo has spent considerable time developing what the customer has asked for. The most diverse hydraulic offering in the end suction markets with an emphasis on pump efficiency and systems integration. Ameriflo manufactures all product type in a wide variety of standard and optional materials offering you the solution you need.

Ameriflo is a global manufacturer of integrated systems with facilities located in several countries and has clients in over 80 countries. The corporate manufacturing headquarters is located in Tennessee, along with a very large testing and training facility for distributor and representative training.

Ameriflo uses computational fluid dynamics (CFD) and 3D Solids Works for designing all pumps and systems with detail for all valves, suction & discharge piping and any installed optional accessories specified by the end user. Electric and Diesel engine driven systems are available and can be ordered in a variety of flows and pressures with full optional metallurgy support.

Product Line

The benefit to the Ameriflo offering is that you only need to go to one place for your product line needs. Whether your need is an end suction pump, a large split case or even a vertical turbine Ameriflo has a model for you. Each product line has a very diverse offering from the very small to the very large and everything in between. Do not rely on other manufacturers who have broken product lines with missing models.

Ameriflo also has state-of-the-art engineered customer service.

www.ameriflo-usa.com



The applications engineering part of Ameriflo have decades of engineering and specification work. This background and experience is critical when the design engineer is looking for answers to questions.

Ameriflo has one of the largest test facilities in North America with nearly 300,000 gallons of water utilizing 8 different test loops from 2 inch through 36 inch. The horizontal and vertical test labs have ratings up through 1,000 HP and include string test stands allowing testing with the job motor or Diesel engine.

Communication Is The Key To Our Success

Ameriflo has systems in place making communication with our clients of the utmost priority. Each client has their own customer portal that will allow them to check on all quotations, sales orders and any client case that is generated. These tools put the power in the hands of the client and allow them access to the most current information. This access empowers our clients to respond to their customers in a more timely fashion and secure that next opportunity!

Ameriflo also has a dedicated

theater used for sales and service training. This theater can house approximately 35 students and is used to cover the Ameriflo pump and Diesel engine product lines. Schools are available to sales people and dedicated service schools are also offered. Service schools feature a hands on portion allowing students to disassemble and re-assemble pumps and/or Diesel engines to allow for certified repairs in the field. Contact Ameriflo to inquire about the next school and how you can join in these events.

Ameriflo also has a state-of-the-art software selection package with full configuration, **Ameriflo IQ**, that can be used by simply signing up. E-mail us for additional information.

If you would like more information about what Ameriflo is all about, please contact us.

What separates Ameriflo from the competition, **WE DELIVER.....**

Ameriflo Corporation

125 Morrison Road
Rossville, TN 38066
Phone: (888) 301-6311
www.ameriflo-usa.com

support@ameriflo-usa.com

3022 EC End Suction
07/01/2023 Revision 1A