

SERIES 8050

SINGLE CARTRIDGE

MECHANICAL SEALS

Sizes: 1.375" to 4.000"
Pressures: To 425 PSI
Speeds: To 4800 FPM
Temp: -40°F to 400°F

Services:

End Suction
 Vertical Inline
 Split Case
 Multistage
 ANSI Process
 Vertical Turbine

ROTARY HEAD

- Fully balanced rotating face
- Wide variety of face material options
- Wide variety of elastomeric options
- Pinned rotary and pinned stationary face allow for maximum performance under the most aggressive applications

SEAL GLAND

- All 316 stainless steel construction
- Integral flush port for maximum seal lubrication
- Gland annulus allows for higher volumes of flush volume to completely cool the entire seal face
- Universal gland is designed to bolt up to standard ANSI process end suction pump rear covers
- Utilizes an o-ring against a static face for maximum sealing

Elastomer Temperature Limits	
Material	Temperature Limits
Buna-Nitrile	-40°C To 107°C -40°F To 225°F
Fluoro-Elastomer	-29°C To 205°C -20°F To 400°F
Ethylene-Propylene	-45°C To 150°C -49°F To 300°F
Neoprene	-40°C To 100°C -40°F To 212°F

Seal De-Rating (Standard Materials)			
Lubricity of Fluid	Gasoline, Kerosene, Oil Or Better	x 1.00	
	Aqueous, Water, etc.	x 0.75	
	Light Hydrocarbons	x 0.60	
Fluid Temperature	Below 79C/175F	x 1.00	
	Above 79°C to 121°C/175°F to 250°F	x 0.90	
	Above 121°C to 177°C/250°F to 350°F	x 0.80	
	Above 177°C/350°F	x 0.65	
Seal Size & Rotational Speedf	Seal Size	1800 RPM	3600 RPM
	1.000 To 2.000	x 1.00	x 1.00
	2.125 To 2.875	x 0.85	x 0.85
	3.000 To 4.000	x 0.61	x 0.61

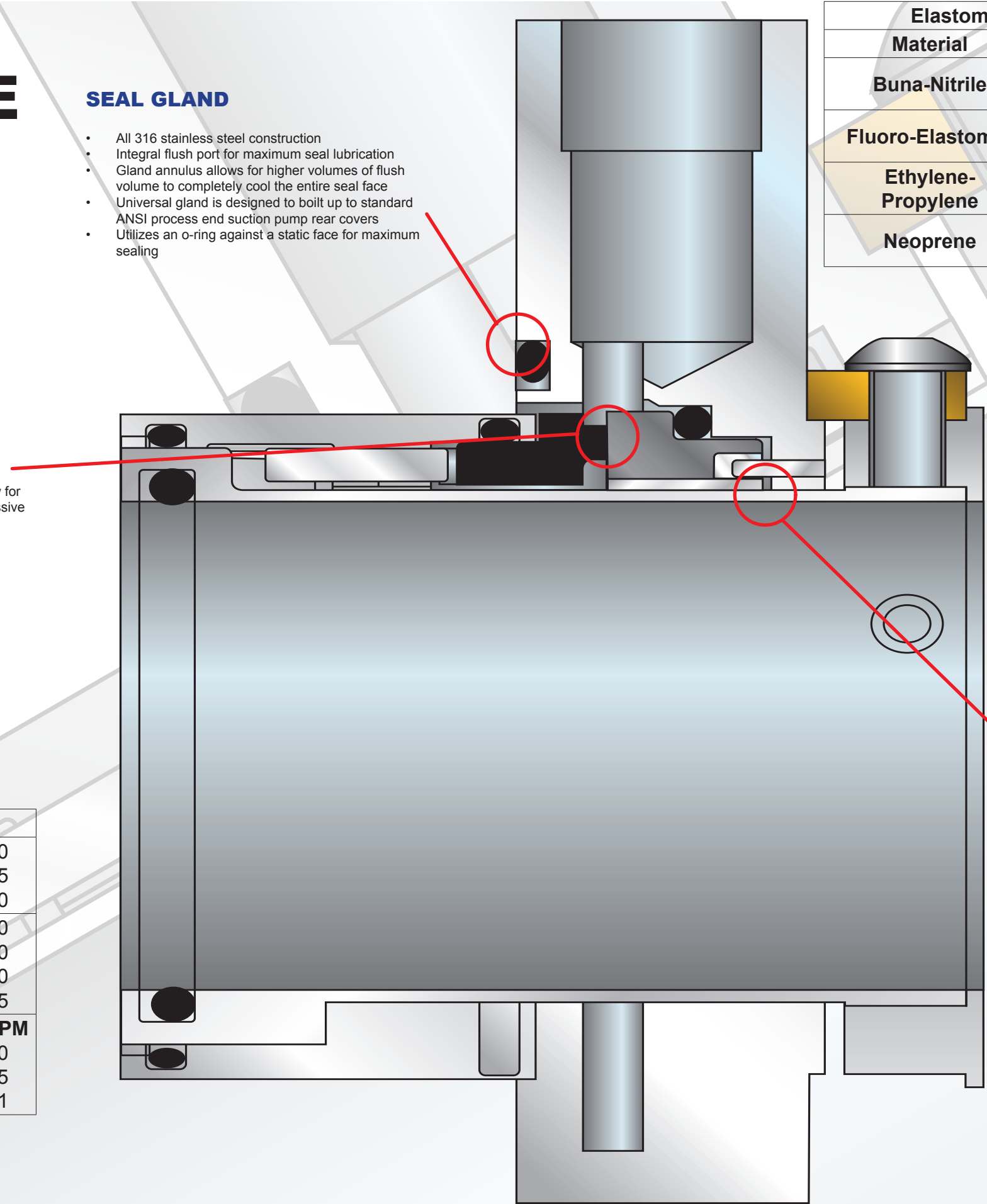

SEAL COLLAR & SHAFT SLEEVE

- All 316 stainless steel construction
- Installation blocks make seal installation very easy and allows for easy impeller adjustment
- Multiple springs for even seal head pressure are completely isolated from the pumped fluid
- Static, non-fretting shaft sleeve o-ring