



# **8060 Series Balanced Double Cartridge Mechanical Seals**

**Temperatures to: -40°F to 400°F  
Pressures to: 425 PSI  
Speeds to: 4800 FPM**

# SERIES 8060

## DOUBLE CARTRIDGE

### MECHANICAL SEALS

**Sizes:** 1.375", 1.875" & 2.625"  
**Pressures:** To 425 PSI  
**Speeds:** To 4800 FPM  
**Temp:** -40°F to 400°F

**Services:**  
 End Suction  
 Vertical Inline  
 Split Case  
 Multistage  
 ANSI Process  
 Vertical Turbine

#### SEAL GLAND

- All 316 stainless steel construction
- Integral flush port for maximum seal lubrication
- Gland annulus allows for higher volumes of flush volume to completely cool the entire seal face
- Universal gland is designed to bolt up to standard ANSI process end suction pump rear covers
- Utilizes an o-ring against a static face for maximum sealing

Elastomer Temperature Limits	
Material	Temperature Limits
Buna-Nitrile	-40°C To 107°C -40°F To 225°F
Fluoro-Elastomer	-29°C To 205°C -20°F To 400°F
Ethylene-Propylene	-45°C To 150°C -49°F To 300°F
Neoprene	-40°C To 100°C -40°F To 212°F

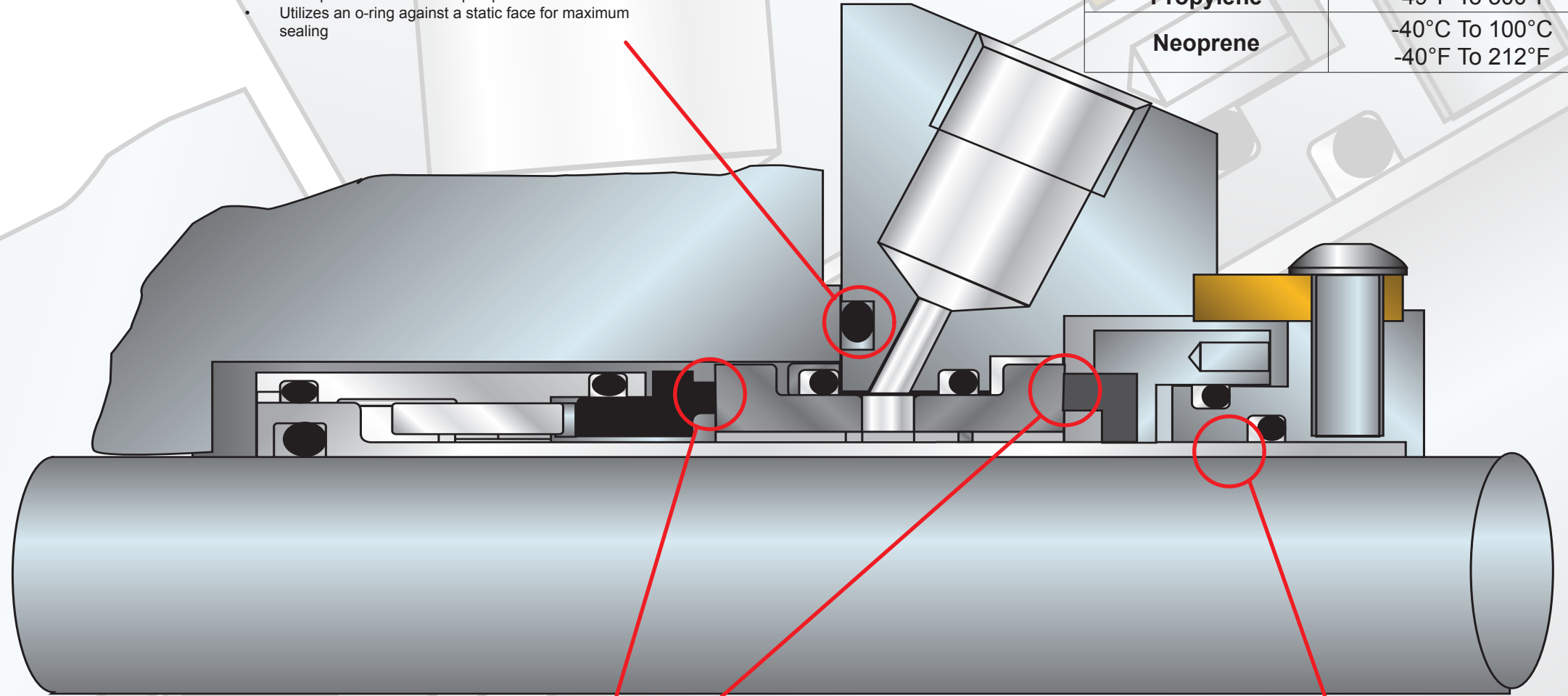

#### Seal De-Rating (Standard Materials)

Lubricity of Fluid	Gasoline, Kerosene, Oil Or Better	x 1.00	
	Aqueous, Water, etc.	x 0.75	
	Light Hydrocarbons	x 0.60	
Fluid Temperature	Below 79C/175F	x 1.00	
	Above 79°C to 121°C/175°F to 250°F	x 0.90	
	Above 121°C to 177°C/250°F to 350°F	x 0.80	
	Above 177°C/350°F	x 0.65	
Seal Size & Rotational Speedf	<b>Seal Size</b>	<b>1800 RPM</b>	<b>3600 RPM</b>
	1.000 To 2.000	x 1.00	x 1.00
	2.125 To 2.875	x 0.85	x 0.85
	3.000 To 4.000	x 0.61	x 0.61

#### ROTARY HEAD

- Two sets of rotary and two sets of stationary seal faces
- Fully balanced rotating face
- Wide variety of face material options
- Wide variety of elastomeric options
- Pinned rotary and pinned stationary face allow for maximum performance under the most aggressive applications

#### SEAL COLLAR & SHAFT SLEEVE

- All 316 stainless steel construction
- Installation blocks make seal installation very easy and allows for easy impeller adjustment
- Multiple springs for even seal head pressure are completely isolated from the pumped fluid
- Static, non-fretting shaft sleeve o-ring



## How It All Began EFFICIENCY BY DESIGN

With years of manufacturing experience, Ameriflo has spent considerable time developing what the customer has asked for. The most diverse cartridge mechanical seal program available. Ameriflo manufactures mechanical seals in wide variety of standard and optional materials offering you the solution you need.

Ameriflo is a global manufacturer of integrated systems with facilities located in several countries and has clients in over 80 countries. The corporate manufacturing headquarters is located in Tennessee, along with a very large testing and training facility for distributor and representative training.

Ameriflo uses computational fluid dynamics (CFD) and 3D Solids Works for designing all pumps and systems with detail for all valves, suction & discharge piping and any installed optional accessories specified by the end user. Electric and Diesel engine driven systems are available and can be ordered in a variety of flows and pressures with full optional metallurgy support.

### Product Line

The benefit to the Ameriflo offering is that you only need to go to one place for your product line needs. Whether your need is an end suction pump, a large split case or even a vertical turbine Ameriflo has a model for you. Each product line has a very diverse offering from the very small to the very large and everything in between. Do not rely on other manufacturers who have broken product lines with missing models.

Ameriflo also has state-of-the-art engineered customer service. The applications engineering part of Ameriflo have decades of

[www.ameriflo-usa.com](http://www.ameriflo-usa.com)



engineering and specification work. This background and experience is critical when the design engineer is looking for answers to questions.

Ameriflo has one of the largest test facilities in North America with nearly 300,000 gallons of water utilizing 8 different test loops from 2 inch through 36 inch. The horizontal and vertical test labs have ratings up through 1,000 HP and include string test stands allowing testing with the job motor or Diesel engine.

### Communication Is The Key To Our Success

Ameriflo has systems in place making communication with our clients of the utmost priority. Each client has their own customer portal that will allow them to check on all quotations, sales orders and any client case that is generated. These tools put the power in the hands of the client and allow them access to the most current information. This access empowers our clients to respond to their customers in a more timely fashion and secure that next opportunity!

Ameriflo also has a dedicated theater used for sales and service training. This theater can house

approximately 35 students and is used to cover the Ameriflo pump and Diesel engine product lines. Schools are available to sales people and dedicated service schools are also offered. Service schools feature a hands on portion allowing students to disassemble and re-assemble pumps and/or Diesel engines to allow for certified repairs in the field. Contact Ameriflo to inquire about the next school and how you can join in these events.

Ameriflo also has a state-of-the-art software selection package with full configuration, **Ameriflo IQ**, that can be used by simply signing up. E-mail us for additional information.

If you would like more information about what Ameriflo is all about, please contact us.

What separates Ameriflo from the competition, **WE DELIVER.....**

### Ameriflo Corporation

125 Morrison Road  
Rossville, TN 38066  
Phone: (888) 301-6311  
[www.ameriflo-usa.com](http://www.ameriflo-usa.com)

[support@ameriflo-usa.com](mailto:support@ameriflo-usa.com)